

LEPUS INDUSTRIALE BR (36V)



Gearmotor in oil bath for condominium sliding gates for max leaf weight **up to 1000 kg**

- Equipped with metal case
- Industrial-Heavy Duty applications
- Oil-bath lubrication in the gears reductions and electric motor
- Absolute Encoder built-in (POSITION GATE RT), for speed control during opening/closing and function of reversal on obstacle. The electronic device allows to build plants in compliance with the requirements of the (UNI EN 12453:2017) regarding safety and impact forces.



| SPECIFICATIONS | LEPUS IND. 1000 BR |
|---------------------|-----------------------------------|
| Power supply | 36V - 230V ($\pm 5\%$) 50/60 Hz |
| Motor Power | 330 W (36V) |
| Opening time | 0,30 m/s |
| Max duty cycles | 100 % |
| Working temperature | -20°C /+ 55°C |
| Weight | 17 kg |
| Max weight | 1000 kg |
| Protection class | IP55 |
| Pinion | Z16 |
| Max thrust | 70 Nm |
| Limit switch | Absolute Encoder |

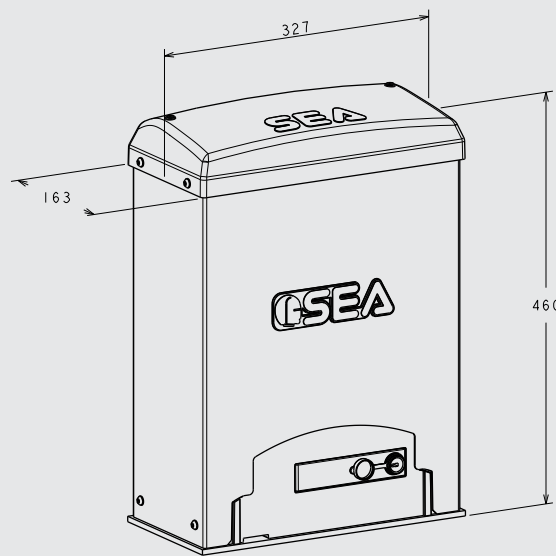

DIMENSIONS (mm)



Control unit
UNIGATE BR



Absolute Encoder
POSITION GATE RT



BRUSHLESS technology