

COMPACT 800 BR (36V)

Hydraulic swing gate operator for condominium use and for leaf lengths up to max **4 meters** or max **800 kg**

- Mechanical limit switches in opening and closing IP 67
- Additional battery back-up with solar panel KIT SUNNY
- Operator to combined with digital control unit UNIGATE BR to manage brushless operators
- Swing operator for intensive use



Mechanical and electronic limit switches IP67



Control board UNIGATE BR to manage brushless operators

SPECIFICHE	COMPACT BR
Power supply	230Vac±5% - 50/60Hz
Motor power	260 W (36V)
Max gate Weight	800 kg
Max duty cycles	100 % (UNIGATE)
Working temperature	-20°C /+ 55°C
Weight	13,8 kg
Max leaf length	4,0 m
Opening degrees	110°
Velocità angolare	max 9° /sec
Protection class	IP67
Max thrust	60 daN (36V)

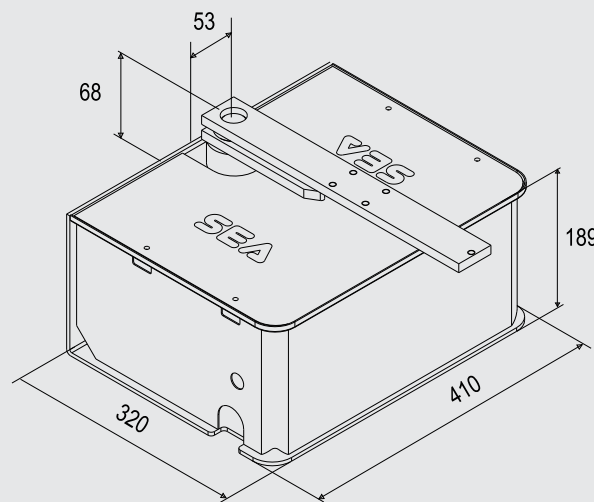

Carrying box in stainless steel



BRUSHLESS technology