

SURF 350 H BR (36V)

Electromechanical swing gate operator for leaf length up to **3,5 m** or max. **300 kg**

- Strong endless screw supported by bearings for max. resistance
- Version H equipped with mechanical and electronic limit switches IP67
- Die-cast aluminium body, weather resistant polyester paint
- Adjustable back fixing with holes



Metal gear drive with reinforced screw supported by ball bearings for maximum strength.



Mechanical and electronic limit switches IP67 (version H)



Screw with ball bearing

SPECIFICATIONS	SURF 350 H BR
Power supply	230Vac±5% - 50/60Hz
Motor power	260 W (36V)
Shaft Stroke	400 mm
Max duty cycles	100 %
Working temperature	-20°C /+ 55°C
Weight	7,5 kg
Max leaf length	3,5 m
Opening degrees	90° - 120°
Shaft speed	adjustable
Protection class	IP44
Max thrust	3000 N (36V)

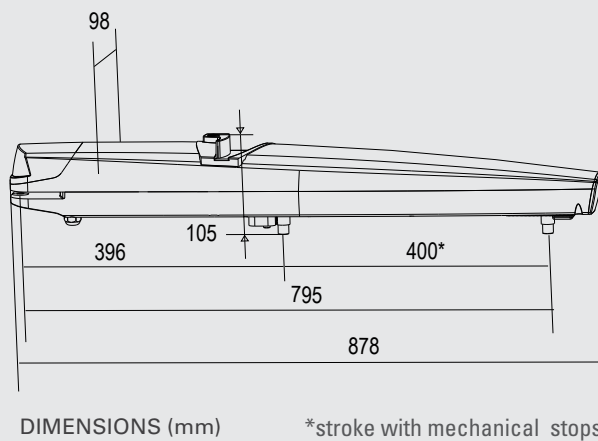

* (NOTE) Duty cycle is calculated as intermittence operating rate (%) on the 1st. hour



BRUSHLESS technology